

MONTUR R LED

DEEL
PARTIE
TEIL
PART
PARTE
PARTE

A

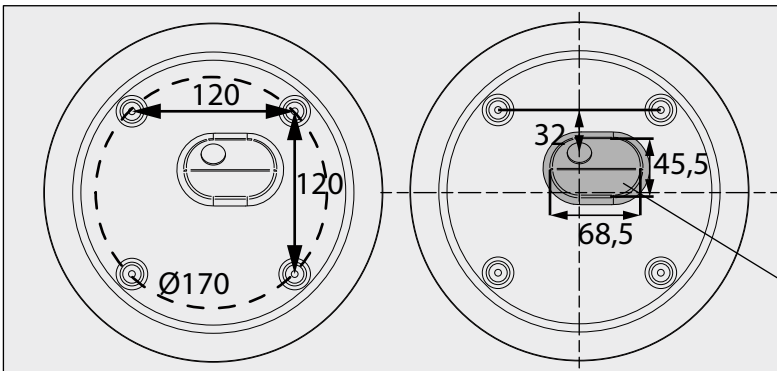
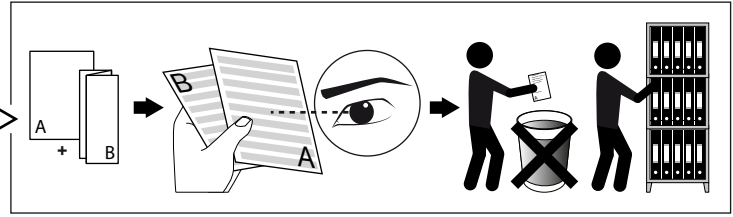
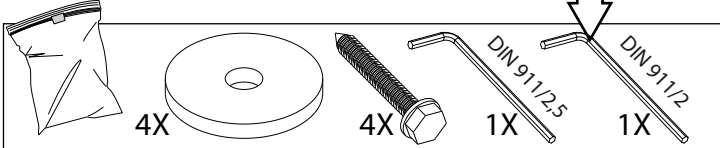

CABLE ENTRY

I _o	350mA
P _o	6,3W
U _i	100-240V

IP65

Stofdicht - Beschermd tegen waterstralen
 Etanche aux poussières - Protégé contre les jets d'eau
 Staubdicht - Geschützt gegen Wasserstrahl
 Dust-tight - Protected against water jets
 Hermético al polvo - Protegido contra chorros de agua
 A tenuta di polvere - Protetto contro i getti d'acqua

Voorzien van aardingsaansluiting
 Avec mise à la terre
 Ausgerüstet mit Erdungsanschluss
 Provided with grounding
 Con la toma de tierra
 Con presa a terra

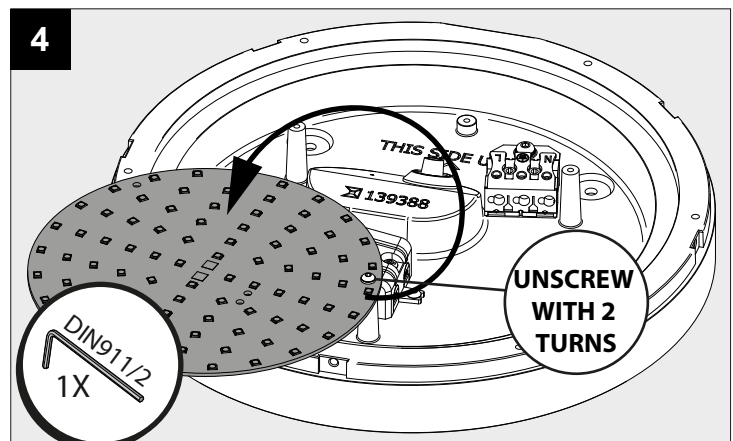
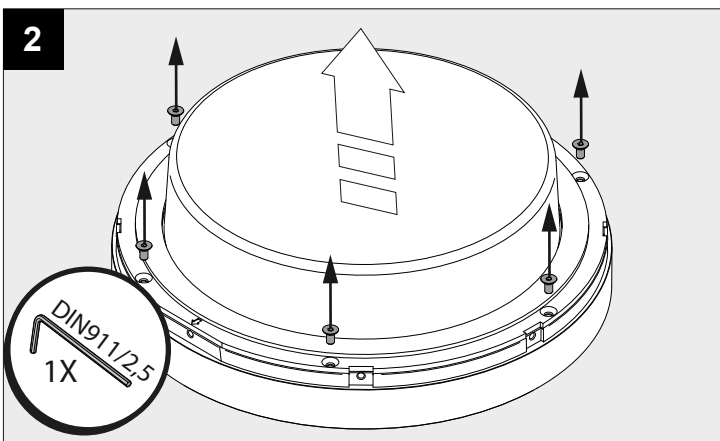
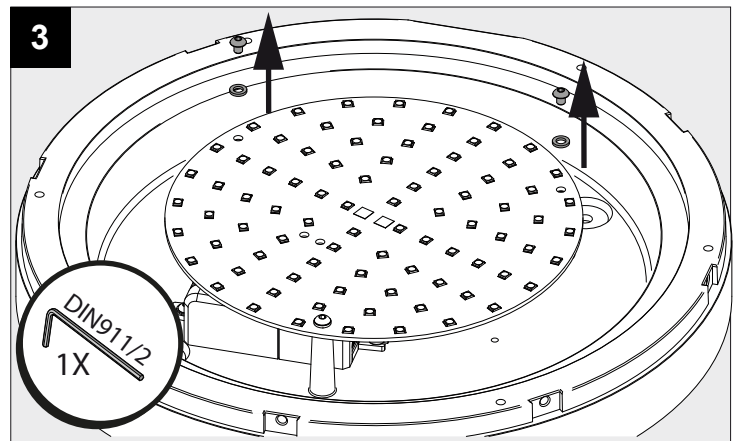
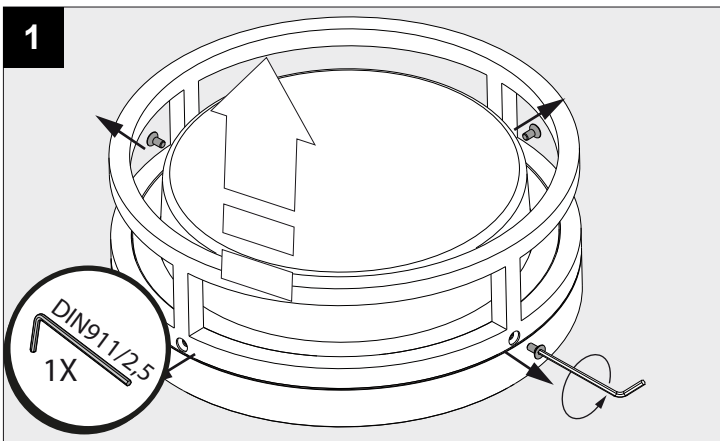

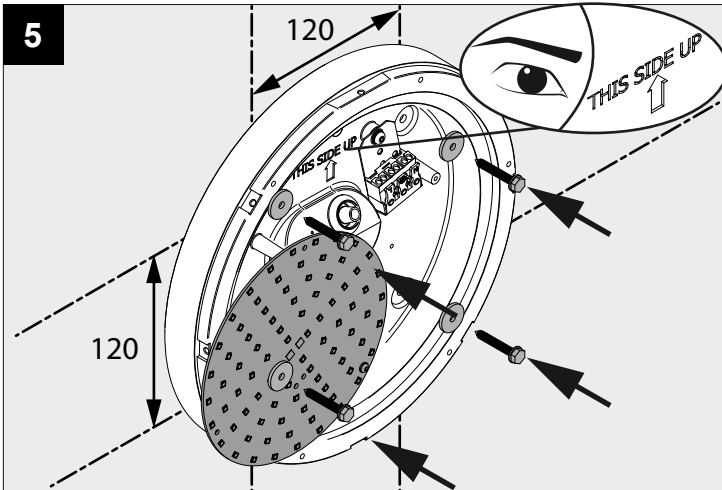

CAUTION! DO NOT PERFORATE THE PROTECTIVE COATING

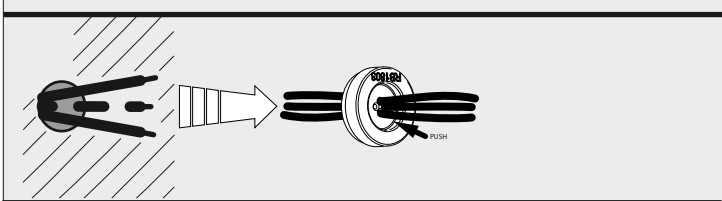
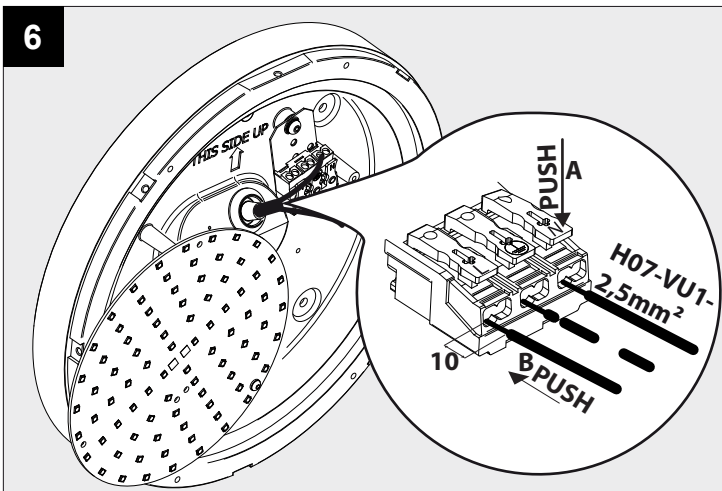
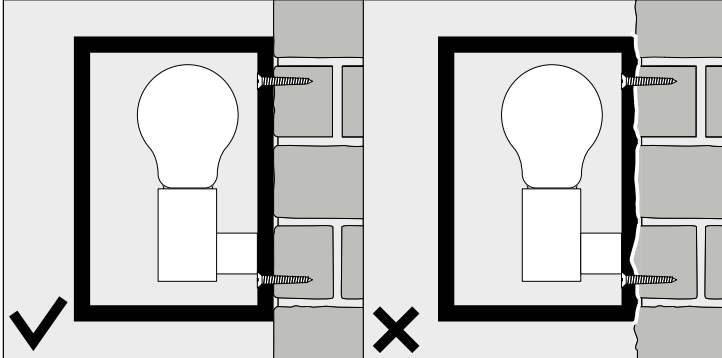

OR

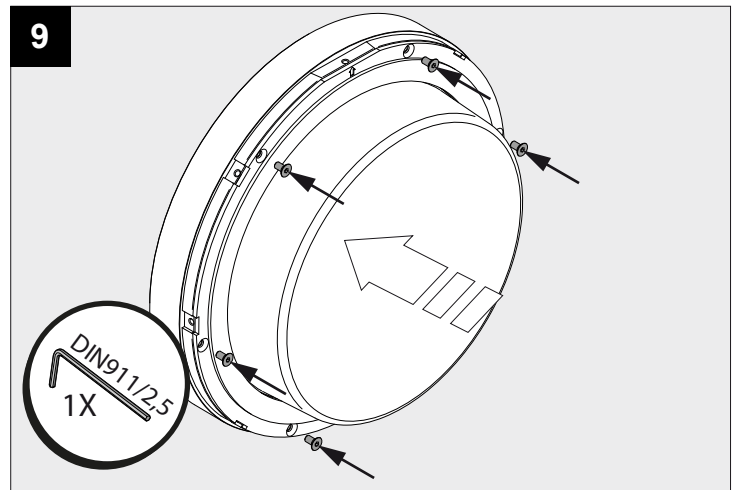
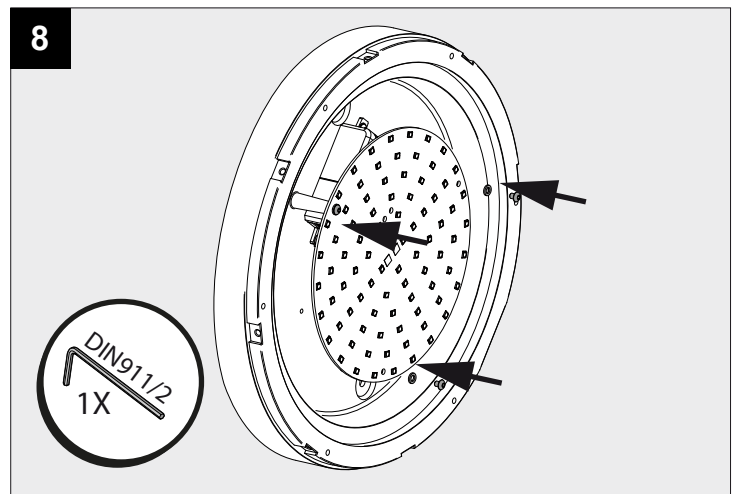
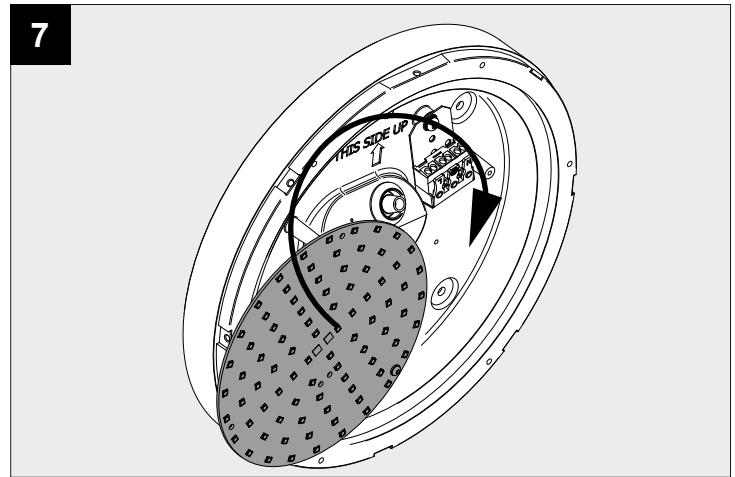
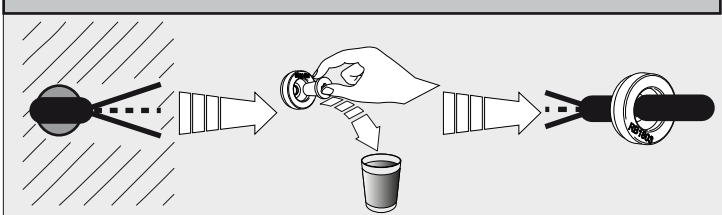

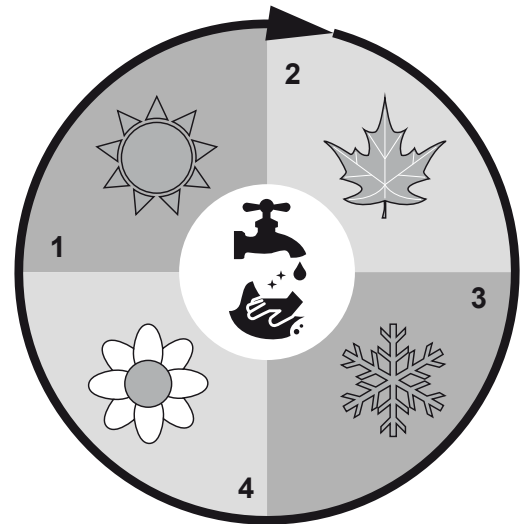
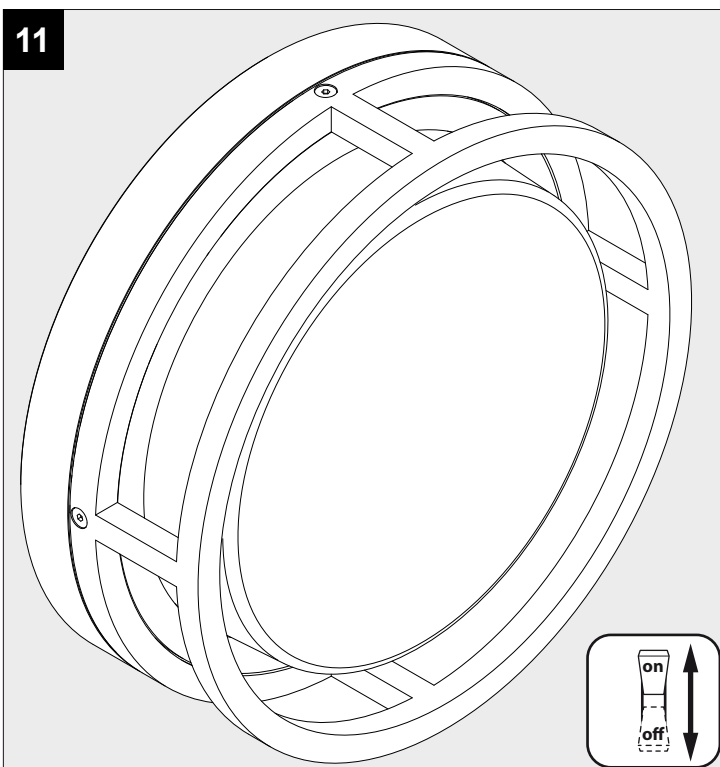
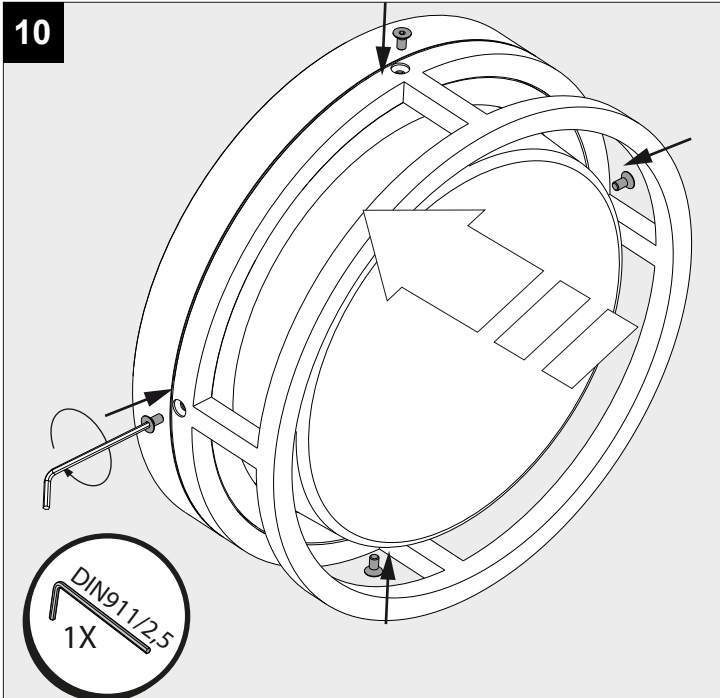

CAUTION! CLEAN AT LEAST QUARTERLY WITH WATER AND NON-ABRASIVE CLOTH

De verlichtingsbron van dit verlichtingstoestel zal enkel door de fabrikant of door de fabrikant aangestelde installateur vervangen worden.

La source lumière de cet appareil ne sera remplacée que par l'entreprise ou par un agent reconnu.

Das enthaltene Leuchtmittel sollte nur durch entsprechendes Fachpersonal ersetzt werden.

The light source contained in this luminaire shall only be replaced by the manufacturer or his service agent.

La fuente de iluminación que tiene esta luminaria sólo puede remplazarse por el fabricante o por un instalador autorizado.

La sorgente luminosa incorporata in questo apparecchio può essere sostituita solo dal produt tore, da un suo centro assistenza oppure da una persona in possesso della necessaria abilitazione.

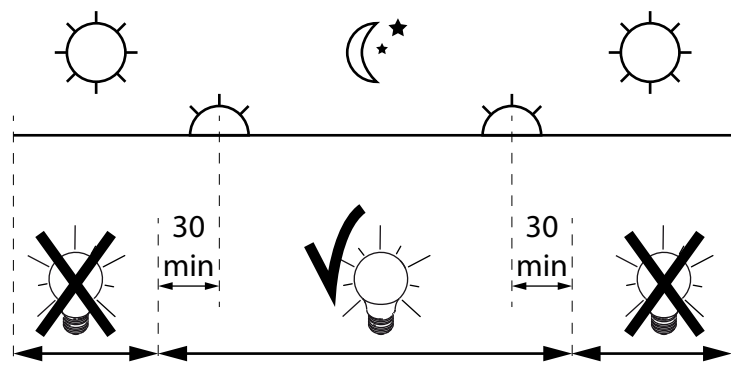

Dagelijkse ontstekingsperiode toegestaan
 Durée quotidienne d'allumage admissible
 Erlaubte tägliche einschaltdauer
 Allowed daily operation period
 Period giornaliero di accensione ammesso
 Periodo diario de encendido permitido