

**MONTUR M LED**

DEEL  
PARTIE  
TEIL  
PART  
PARTE  
PARTE

# A

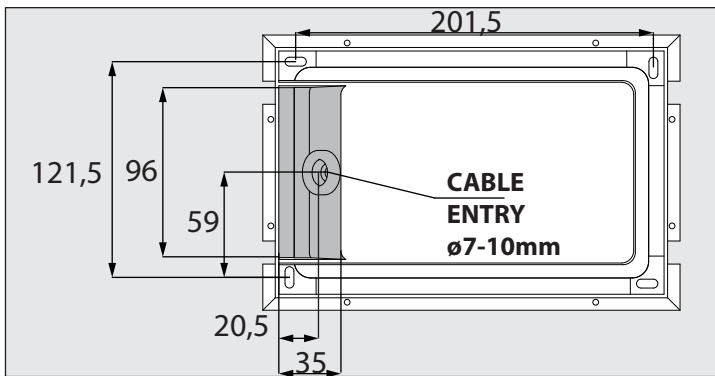
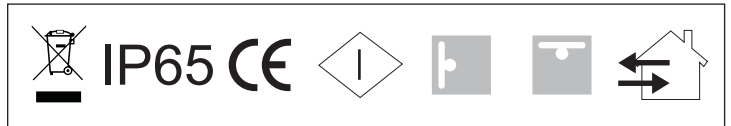
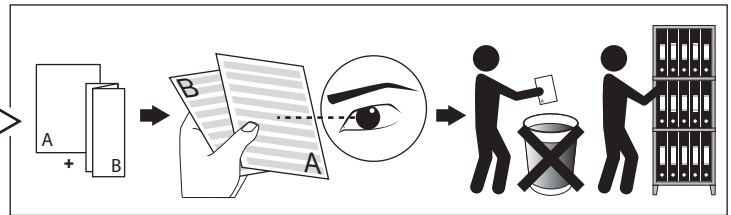

**U : 100 - 240V**

**IP65**

Stofdicht - Beschermd tegen waterstralen  
 Etanche aux poussières - Protégé contre les jets d'eau  
 Staubdicht - Geschützt gegen Wasserstrahl  
 Dust-tight - Protected against water jets  
 Hermético al polvo - Protegido contra chorros de agua  
 A tenuta di polvere - Protetto contro i getti d'acqua

**I**

Voorzien van aardingsaansluiting  
 Avec mise à la terre  
 Ausgerüst tet mit Erdungsanschluss  
 Provided with grounding  
 Con la toma de tierra  
 Con presa a terra

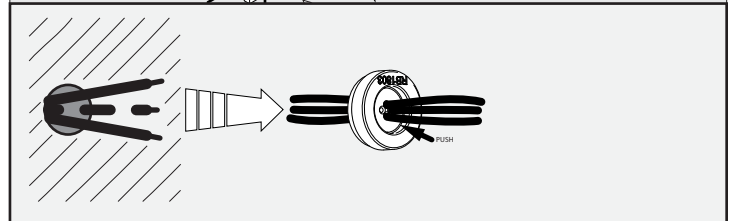
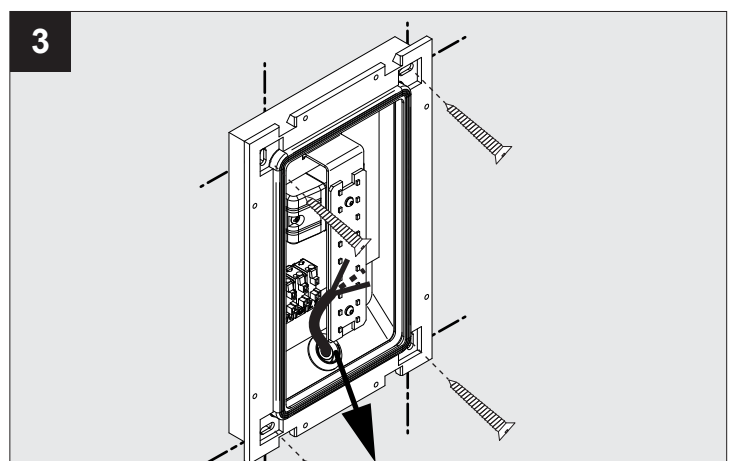
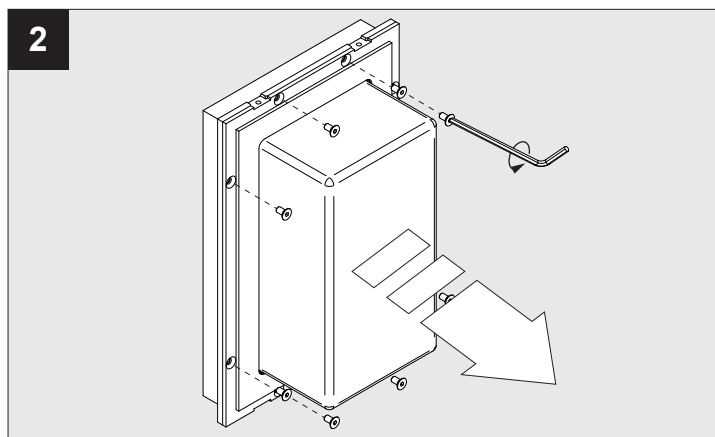
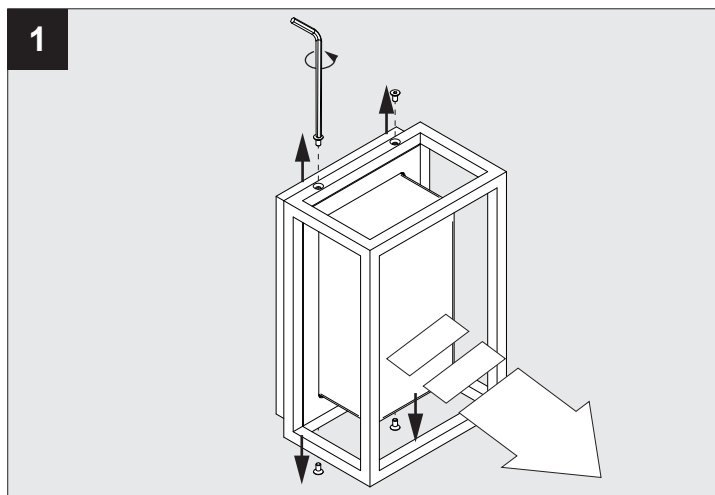

OR

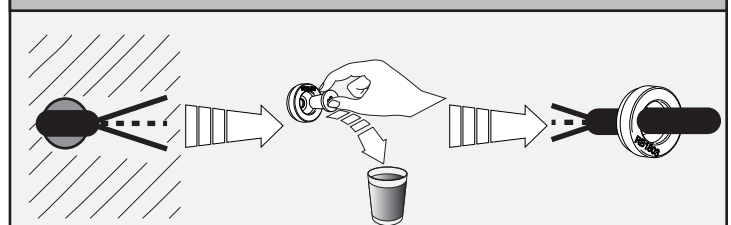

**CAUTION! DO NOT PERFORATE THE PROTECTIVE COATING**

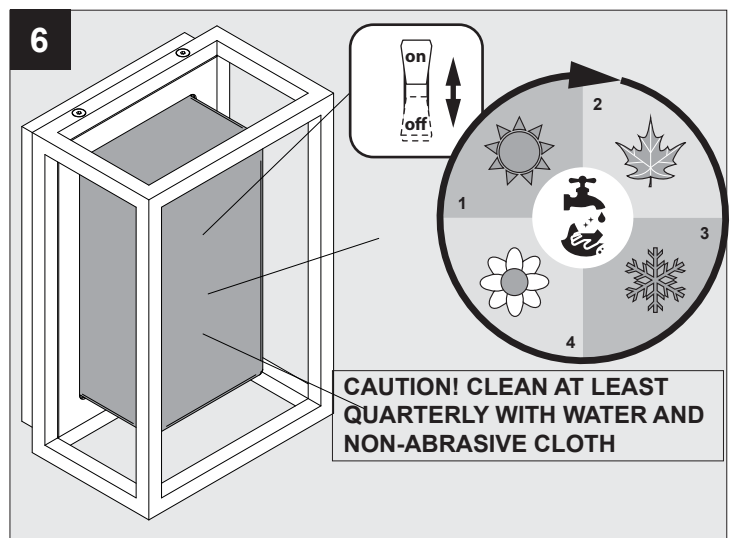
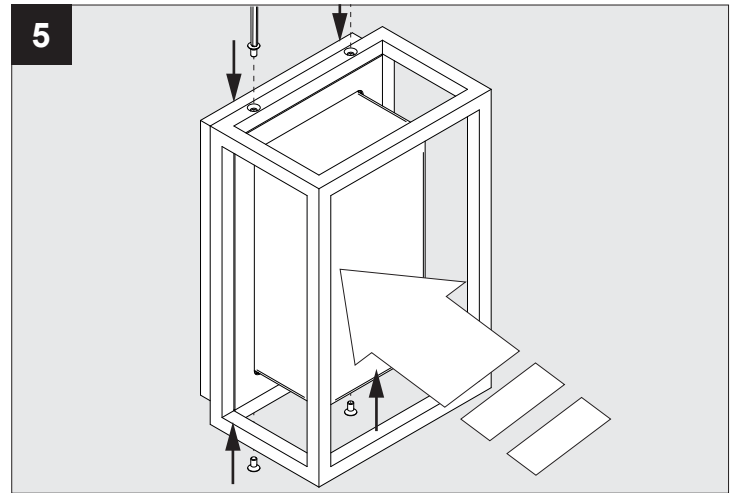
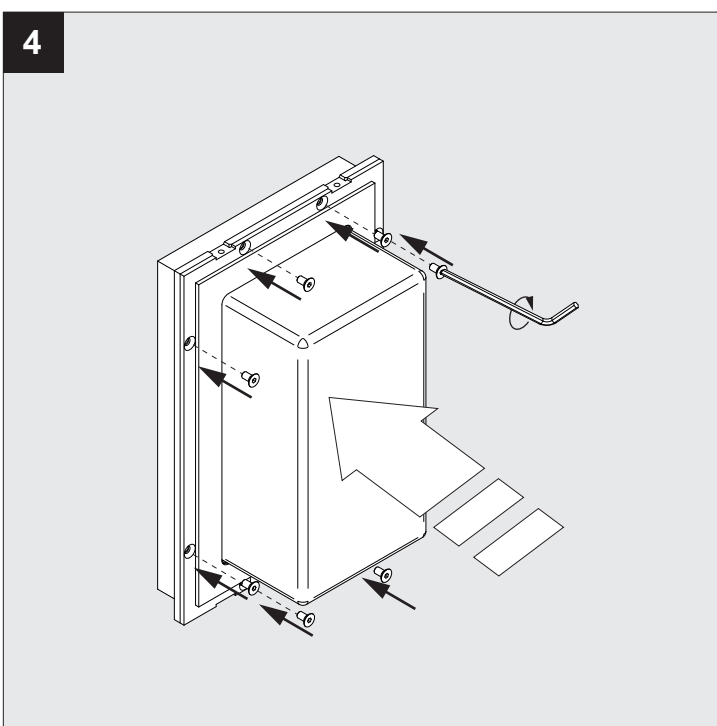
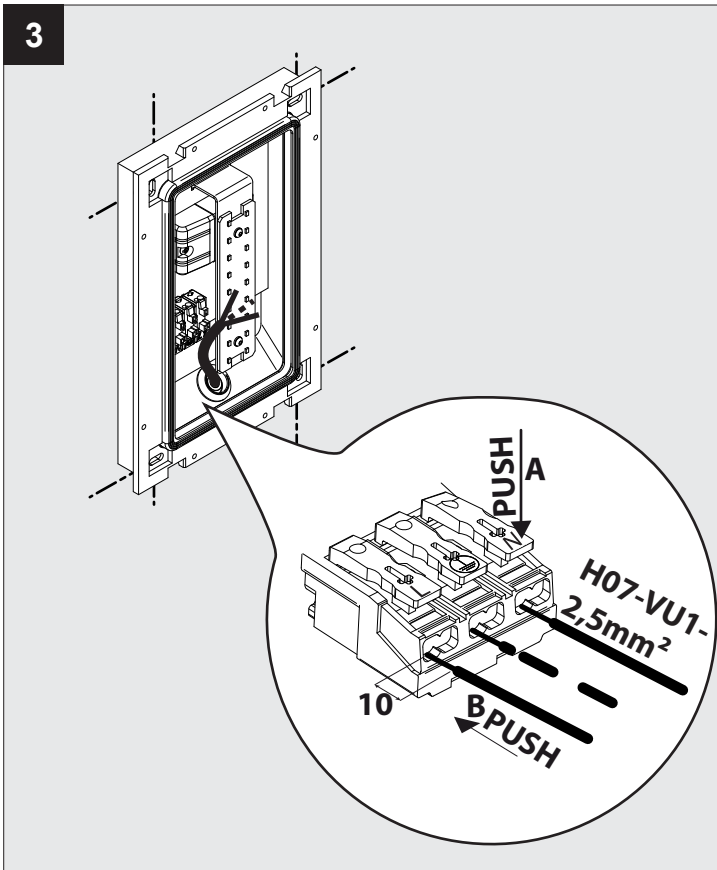
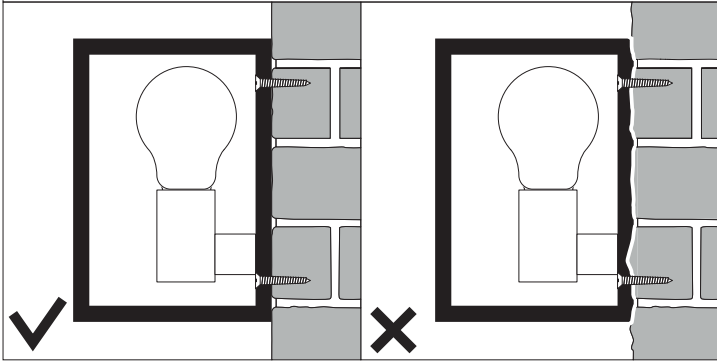

De verlichtingsbron van dit verlichtingstoestel zal enkel door de fabrikant of door de fabrikant aangestelde installateur vervangen worden.

La source lumière de cet appareil ne sera remplacée que par l'entreprise ou par un agent reconnu.

Das enthaltene Leuchtmittel sollte nur durch entsprechendes Fachpersonal ersetzt werden.

The light source contained in this luminaire shall only be replaced by the manufacturer or his service agent.

La fuente de iluminación que tiene esta luminaria sólo puede remplazarse por el fabricante o por un instalador autorizado.

La sorgente luminosa incorporata in questo apparecchio può essere sostituita solo dal produttore, da un suo centro assistenza oppure da una persona in possesso della necessaria abilitazione.

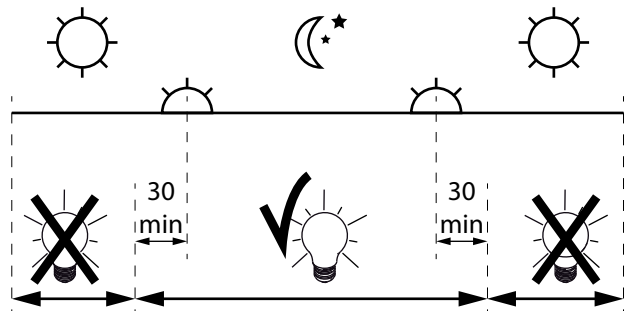

Dagelijkse ontstekingsperiode toegestaan  
 Durée quotidienne d'allumage admissible  
 Erlaubte tägliche einschaltdauer  
 Allowed daily operation period  
 Period giornaliero di accensione ammesso  
 Periodo diario de encendido permitido